

STRAIGHT BULKHEAD JACK PANEL SEAL

R125.326.901

CRIMP TYPE - CABLE .085

Series : SMA

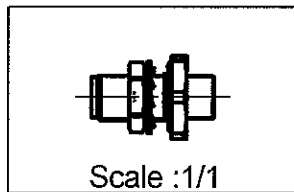
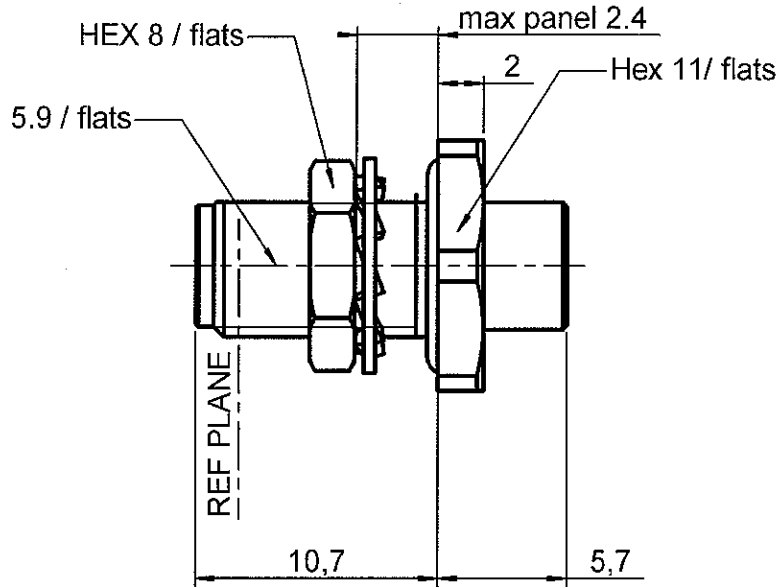

PANEL CUT OUT

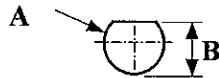

mm		
	Maxi	mini
A	6.5	6.4
B	6.15	6

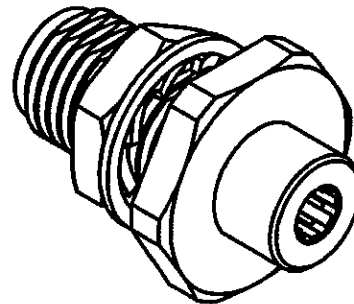

All dimensions are in mm.

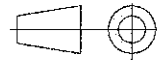

COMPONENTS	MATERIALS	PLATINGS (µm)
BODY	STAINLESS STEEL	PASSIVATED .
CENTER CONTACT	BERYLLIUM COPPER	GOLD 2.5 OVER NICKEL 2
OUTER CONTACT	-	-
INSULATOR	PTFE	
GASKET	SILICONE RUBBER	
OTHERS PARTS	STAINLESS STEEL	PASSIVATED .
-	-	-
-	-	-

Issue : 0608 D

In the effort to improve our products, we reserve the right to make changes judged to be necessary.



STRAIGHT BULKHEAD JACK PANEL SEAL

R125.326.901

CRIMP TYPE - CABLE .085

Series : SMA

PACKAGING

Standard	Unit	Other
100 100	'W' option	Contact us

SPECIFICATION

CABLE ASSEMBLY

ELECTRICAL CHARACTERISTICS

Impedance	50	Ω
Frequency	0-18	GHz
VSWR	1.07 + 0,0100	x F(GHz) Maxi
Insertion loss	0.03	√F(GHz) dB Maxi
RF leakage	- (60	- F(GHz)) dB mini
Voltage rating	335	Veff Maxi
Dielectric withstanding voltage	750	Veff mini
Insulation resistance	5000	MΩ mini

Stripping	a	b	c	d	e	f
mm	1,78	0,00	0,00	0,00	0,00	0,00

Assembly instruction :

Recommended cable(s)
KS 1
RG 405

Cable retention

- pull off 130 N mini
- torque NA N.cm

MECHANICAL CHARACTERISTICS

Center contact retention		
Axial force – Mating end	27	N mini
Axial force – Opposite end	27	N mini
Torque	2.8	N.cm mini

Recommended torque		
Mating	NA	N.cm
Panel nut	150	N.cm
Clamp nut	NA	N.cm
A/F clamp nut	0,0000	mm

Mating life	500	Cycles mini
Weight	3,9495	g

TOOLING

Part Number	Description	Hexagon
.	.	.
R282.705.000	POSITIONER	-
R282.286.000	CRIMPING TOOL	-
R282.255.000	PNEUMATIC CRIMPING TOOL	
R282.711.000	GUIDE	
R282.051.000	STRIPPING TOOL	
R282.062.000	POINTER GAUGE	
R282.710.000	GUIDE	

OTHERS CHARACTERISTICS

ENVIRONMENTAL

Operating temperature	-65/+105	° C
Hermetic seal	NA	Atm.cm3/s
Panel leakage	NA	

Issue : 0608 D

In the effort to improve our products, we reserve the right to make changes judged to be necessary.



RADIALL®

STRAIGHT BULKHEAD JACK PANEL SEAL

R125.326.901

CRIMP TYPE - CABLE .085

Series : SMA

COMPONENTS

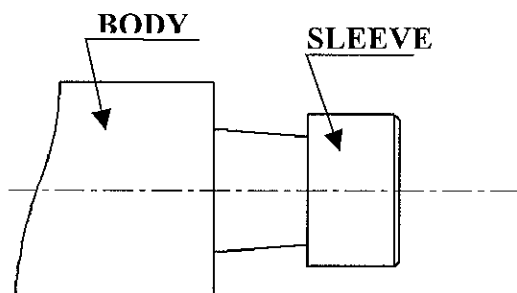

STIPPING DIMENSIONS

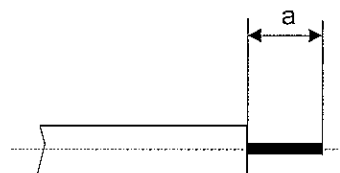

1

- Strip the cable with the cable stripping tool
- Trim the cable inner conductor with the trimmer.
- Clean the cable

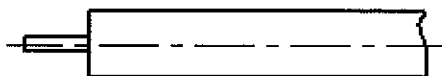

3

- Insert the connector and the cable on the crimping tool with guide and positioner.
- A pneumatic crimping tool exist too that can be used

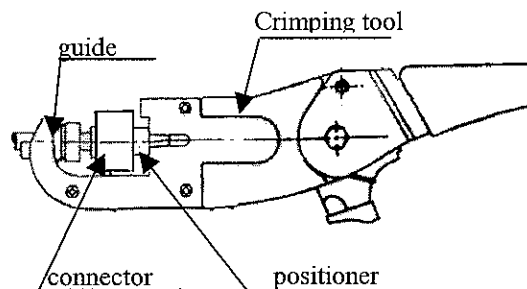

2

- Slide connector onto the cable

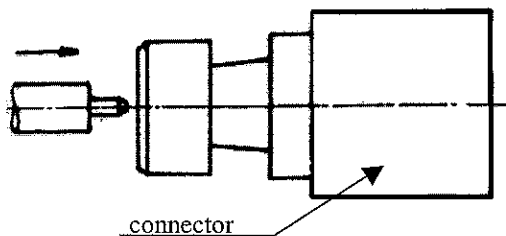

4

- Press the connector on the cable.

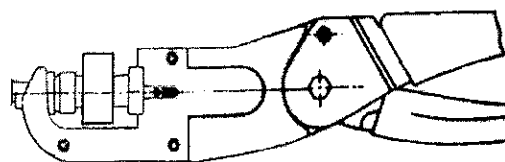

Issue : 0608 D

In the effort to improve our products, we reserve the right to make changes judged to be necessary.



RADIALL®